

High Radiation Resistant DC-DC Converter Regulators for use in Magnetic fields for LHC High Luminosity Silicon Trackers

S. Dhawan^a, O. Baker^a, P. Tipton^a, J. Kierstead^b, D. Lynn^b, S. Rescia^b, M. Weber^c

^aYale University, New Haven, CT USA

^bBrookhaven National Laboratory, Upton, NY USA

^cRutherford Appleton Laboratory, Chilton, Didcot, UK

Satish.Dhawan@yale.edu

Abstract

For more efficient power transport to the electronics embedded inside large colliding beam detectors, we explore the feasibility of supplying higher DC voltage and using local DC-DC conversion to 1.3 V (or lower, depending upon on the lithography of the embedded electronics) using switch mode regulators located very close to the front end electronics. These devices will be exposed to high radiation and high magnetic fields, 10 – 100 Mrads and 2 - 4 Tesla at the SLHC.

I. INTRODUCTION

The driving force behind the rapid development of commercial Buck regulators for DC- DC [1] conversion is the high efficiency necessary to maximize the life of the Lithium Ion batteries used to power cell phone and MP players. The desire of the consumer to have the smallest and lightest cell phones and other consumer electronics requires that all components, including power converters, have the smallest possible footprint and weight. The requirements of high efficiency and small size are the same as that required for the next round of silicon inner tracker detectors at the Super Large Hadron Collider (SHLC).

Power delivery efficiencies to the front-end electronics of the current LHC detectors are on the order of 30 percent. As the front-end ASIC designs have migrated to 0.25 μm lithography, the operating current has increased. For the SLHC the ASICS will be fabricated in either 130 nm or 90 nm technology and the number of detecting elements will increase by an order of magnitude. It is envisioned that the current copper power cables will be re-used due to space constraints as well as installation time constraints. In order to avoid unacceptable ohmic losses in the cables, power must be delivered to the inner detectors at higher voltage and lower current. Conversion to the lower voltage ($\sim 1\text{V}$) and higher current required by the front-end ASICS must occur in the densely packed front-end modules consisting of ASICS and silicon detectors. DC-DC converters [2] are one option for making the necessary voltage conversion.

We have begun a program of investigating the possibility of using commercial Buck regulators. The goals are to understand whether commercial devices are a viable option, either now or in the near future, to understand the effect of high frequency DC-DC conversion on the ATLAS

SCT module performance, and to understand the design criteria in the event a custom designed ASIC proves necessary.

II. REQUIREMENTS FOR Si TRACKERS

There are two requirements on the converter that differ from those of industry that we would like to point out. First is that for the SLHC the converter must survive an unprecedented level of radiation exposure that is on the order of 100 MRad. Second, since the converters will operate in large solenoidal fields between 2-4 Tesla, the converter must use an air coil inductor. This necessitates that it operate at sufficiently high switching frequencies so that it can work with the smaller inductances achievable with a compact air coil [3-5]. We list the primary requirements on the DC-DC converter below.

- ❖ Output voltage ~ 1.3 Volts
- ❖ Input Voltage = 5.5 V or prefer 12 V
- ❖ Output Current range = 0.7 – 6 amps (depends upon module segmentation)
- ❖ Radiation Hardness
- ❖ Magnetic Fields 2-4 Tesla
- ❖ Small enough to fit on each multi-chip module (i.e. hybrid)
- ❖ Low EMR and switching noise

Our goals in investigating buck regulators are the following:

III. OUR DESIGN OBJECTIVES / GOALS

- ❖ Explore commercial buck regulators. Can these work for us?
- ❖ Test commercial devices in a high radiation environment >100 Mega rads
- ❖ Check feasibility of using air coils for use in high magnetic fields
- ❖ Determine if the switching noise will couple into a silicon module
- ❖ Determine what can be learned from existing commercial buck regulators
- ❖ Should no commercial buck regulator prove satisfactory, determine what will be necessary for a custom ASIC design

A. Commercial DC-DC Converter Evaluation Boards

To begin our investigations we purchased several evaluation boards with different DC-DC converters from two manufacturers. The DC-DC converters featured in these evaluation boards are the following:

Table 1: Commercial Devices

Manu- facture	Part No.	Tech- nology	Cur- rent	Freq- uency.	Induct- or
Enpirion	EN5360	0.25 um CMOS	6 A	5 MHz	Ferrite
Enpirion	EN5312	0.25 um CMOS	1 A	4 MHz	Ferrite
Enpirion	EQ5382D	0.25 um CMOS	0.8 A	5 MHz	Ferrite/ Air
Linear Tech	LTC3415E	unknown	7 A	1.5 MHz	Air Coil
Linear Tech	LTM4602	unknown	6 A	0.8 MHz	Ferrite

Some of these have integrated inductors in the package. Others use external inductors which can be replaced with air coils. There are jumpers to select the output voltage or optionally use resistors to get other output voltages.

IV. TESTS DONE IN YEAR 2007

1. Radiation exposure
2. Qualitative EMI
3. EMR (RF Leakage)
4. RF Leakage
5. Noise and pickup tests with ATLAS Silicon Tracker Module at RAL
6. Operation in high magnetic field
7. Load Efficiency

1) Radiation Exposure

We chose to irradiate the EN5360 evaluation board as we knew it to be fabricated in 0.25 um technology that had the potential to be radiation hard. We irradiated the board at the BNL Gamma Irradiation Facility which features a 3000 Curie Co-60 source. The board was irradiated under load with an output voltage of 1.8 V and an output current of 4 amps. The exposure rate was 5 MRad/day. We monitored the output voltage every few minutes, and all other currents and voltages were logged once per day. The output voltage varied no more than 3 mV over 20 day we irradiated the device up to a total of 100 MRad, at which point we ceased the test. This test provided evidence that commercial converters exist that may survive the radiation levels expected at SLHC.

We measured the EN5360 buck regulator efficiency after irradiation over a range of output currents. We have just one measurement of efficiency prior to irradiation. These data are plotted in Figure 1. At about 5A, the only point where we can compare prior and post irradiation efficiency, we see the efficiency is apparently independent of dose. The efficiency is seen to be minimally dependent upon the load.

The only change to the evaluation board that we measured or observed was a discoloration to the solder mask. We show this in Fig. 2 in which the left picture is prior to irradiation, and the right is post-irradiation. The solder mask color under radiation turned from bright green to dark dull green.

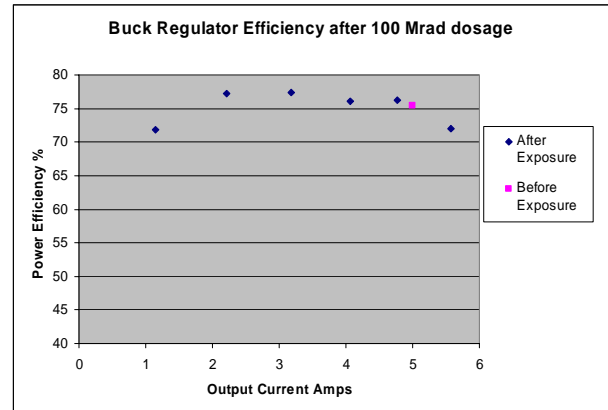

Figure 1: DC-DC converter efficiency as a function of load current

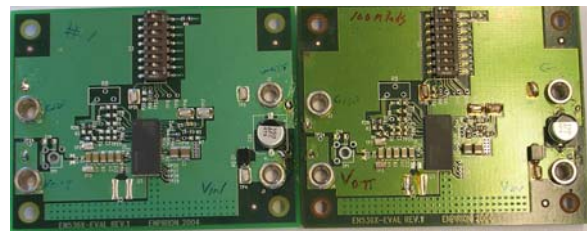

Figure 2: Difference in color mask color before and after exposure to 100 Mrad

2) Qualitative Pickup & Noise with RHIC Polarimeter Silicon and Analog Readout

We performed some initial qualitative tests of sensitivity of silicon detectors to EMR from ferrite and air coil buck regulators. We had access to a set up of the RHIC Polarimeter silicon that had analog readout and Yale-built WFDs (wave form digitizer modules). We found we had more noise measurement sensitivity when we measured the noise on the buffered analog signal with a digital oscilloscope. For these tests, the silicon was unbiased.

We first placed the EN5360 regulator with an integrated ferrite core within millimeters of the unbiased silicon as well as the analog readout electronics and observed no additional noise. We were able to observe noise pickup however when we repeated the test with LTC3415E regulator with air coil inductor. Two layers of standard aluminum foil that we had on hand were sufficient to effectively shield the silicon from pickup. These tests point to the need to carefully consider the air coil design and placement to avoid pickup in adjacent detectors and the need for shielding.

3) EMR (RF Leakage) Test

The RF emissions from test boards were measured by a HP 11944, a closed field RF probe, as a function of various

thicknesses and shielding materials as shown in figure three. The pickup signals were the strongest near the traces between the input and output capacitors. Aluminum foil of 25 μm thickness reduces the pickup from 65 mV to 3 mV; brass was 3 times less effect than aluminum. 1 mm of aluminum shield reduced to a level of 0.3mV. This measurement gave us some level of confidence on how to shield the converter EMR.

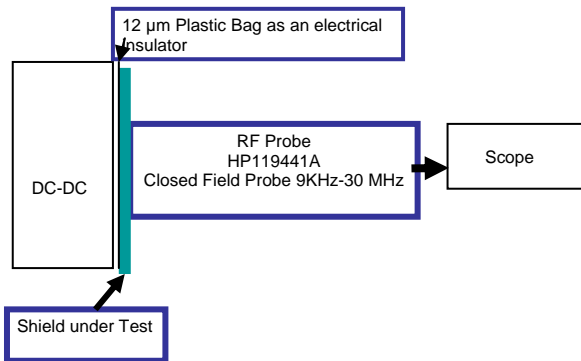

Figure 3: RF Leakage Test Setup

4) Noise and Pickup Tests with ATLAS Silicon Tracker Module at RAL

Rutherford Appleton Laboratory has a VME based readout system for reading the 12 chip ATLAS SCT module. The module consists of two silicon sensors glued back-to-back (with a carbon substrate between), and six ABCD readout chips mounted on a kapton circuit above each sensor (for a total of 12 ABCD chips/module). This module is enclosed in an aluminum box faraday cage.

The following devices were used for the tests for noise injection.

- ❖ EN5360
- ❖ EN5312
- ❖ LTC3415E
- ❖ LTM4602

The ABCD chip requires 4 volts digital and 3.5 volts analog. We supplied the digital voltage to the ABCD chip directly from a laboratory power supply. Data runs were taken with analog voltages derived from DC-DC regulators and from a second laboratory power supply. We found that the noise was the same in all cases and at the level expected for normal operation.

We then opened the top cover of the aluminum box and replaced it with a plastic cover for physical protection of the silicon sensor. The cover was approximately $\frac{1}{2}$ cm above the silicon. The LTC3415E evaluation PCB with the air coil was placed on the top of the plastic cover with the solenoidal air coil facing the silicon sensor. A photograph of the evaluation board is shown in Figure 4. Many data runs were taken with the coil parallel and perpendicular to the silicon strips, and with both a 13 μm and 65 μm aluminum shield between the coil and the detector. No increase in noise was seen with the 65 μm shield. Additional noise was seen in the top detector with the 13 μm shield, but not in the bottom detector. In Figure 5 we plot these results for both detectors using the 13 μm shield, for two cases in which the coil was place perpendicular and

parallel to the silicon strips. The noise increase is larger and more geometrically localized for the perpendicular case. This result requires further analysis. The fact that the bottom detector is unaffected in all cases is either due to the shielding effect of the top detector, the carbon substrate, the increased distance from the coil, or some combination of the three.

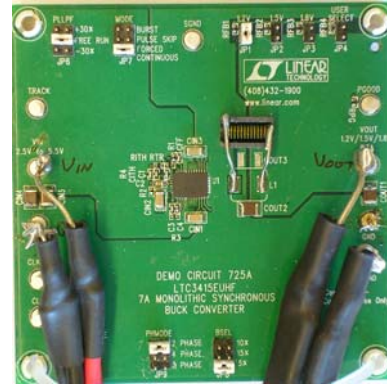

Figure 4: LTC3415E Evaluation Board with Air Coil

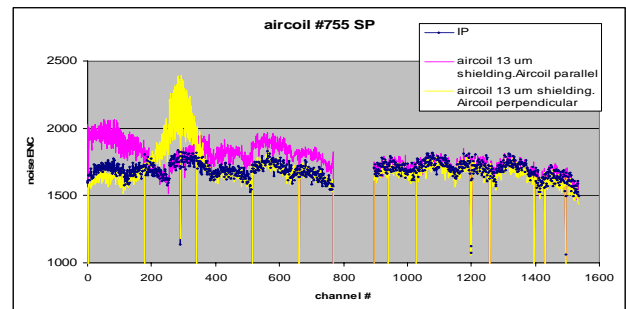

Figure 5: Noise Histogram from Silicon Sensor. Left plot is for top sensor facing the Air Coil. Right side plot is for the sensor below the top sensor.

5) Operation in a High Magnetic Field

We are operating under the assumption that an air coil buck regulator can be run in a 2-4 Tesla magnetic field with no impact on performance. To test this hypothesis, we inserted the LTC3415E air coil buck regulator evaluation board in the Yale Chemistry 7-Tesla superconducting solenoid magnet operating in persistent mode. The regulator was under a 1 amp load at 3.545 output volts. At a nominal 7 Tesla field, the output voltage was 3.546 and 3.549 volts with the board placed at the edge and at the middle of the magnets aperture, respectively. Voltage went up by 4 mV.

This indicates that it is feasible to run air coil regulators in such high magnetic fields.

6) Load Efficiency Tests

At the start of the project, we were mainly interested in the feasibility of using air coils. As our initial tests indicate that in principle it is possible, we are now interested in the power conversion efficiency with higher input/output voltage ratios.

Fig. 6 shows a power efficiency plot of the EQ5382D 0.8 amp regulator with external ferrite versus air coil inductor. The evaluation board came with a 1 μH ferrite

inductor; at the time of the testing we had a small 0.12 μH air solenoid inductor and the results are shown.

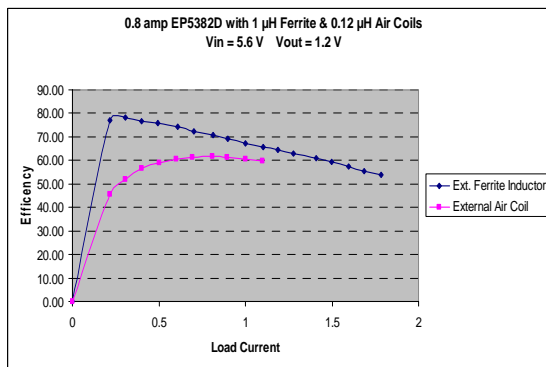

Figure 6: Efficiency of the EQ5382D buck regulator as a function of current using ferrite and air coils

A smaller inductor has more ripple current resulting in higher rms current losses that lead to a lower efficiency.

At the higher currents, other IR losses are greater than the ripple current losses. At 2/3rd of the rated current of the device, the efficiency is above 70% with the ferrite coil and 60% air coil.

Figure 7 shows an efficiency plot for the LTC3415E, a 7 amp air coil device. The air coil is 0.307 μH and the efficiency is plotted with output voltages of 1.2 V and 3.5 V. The latter output voltage was used at RAL for the noise tests with the current ATLAS Silicon Tracker module. The efficiency is above 90% with an output voltage of 3.5 V and is 10% lower at 1.2 Volts.

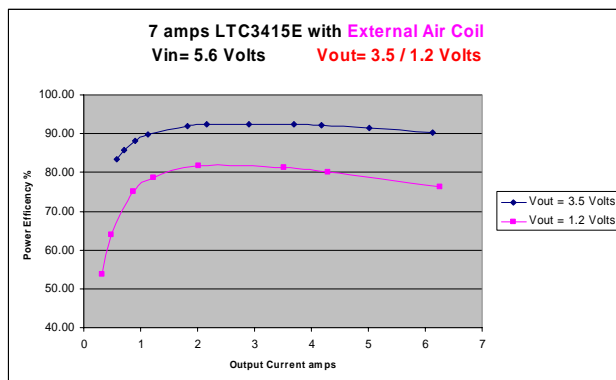

Figure 7: LTC3415E Power Efficiency for outputs of 3.5V and 1.2 V

We are also investigating the effect of efficiency with higher input/ output voltage ratios assuming the output voltage is 1.2V for the 0.130 μm ASIC chips. Results are shown in Fig 8.

The LTM4602V is a 2 cm^2 μModule capable of outputting 6 amps with input voltages up to 15 volts. At an output voltage of 1.2V and 4 amps load current, the power conversion efficiency is 87%, 83% and 81% with input voltages of 5.6, 12 and 15 volts respectively.

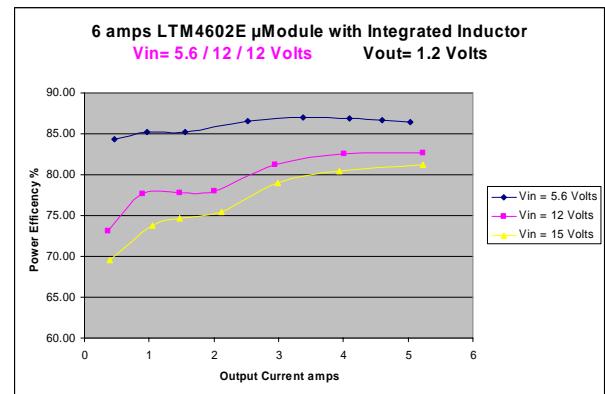

Figure 8: LTM4602V Power Efficiency with various input Voltages

V. COMMENTS ON TECHNOLOGY

We have x-rayed the commercial devices to learn more about the technology being used. These devices are using what is called SIP (system in a package) with a lead frame for EN5360. One or more chips, capacitors and resistors are soldered while multiple wires on the chips were bonded in parallel from the chip to the substrate in order to carry the high output currents. The integrated inductor can be one or more turns of copper wire with ferrite core for high currents as shown in Fig. 10A and Fig.10B. In Fig. 10B the x-ray energy is optimized to see a single turn around a ferrite core. A 1 amp device may use a planar inductor as shown in the figure 10C.

One advantage of the planar inductor is that it can be formed on top of the silicon chip and thus reduce the footprint of the package (a very important factor for cell phones etc.). Many companies are working on MEMS technology for the inductors where 128 μm thick conductors are required for 9 amp buck regulators.

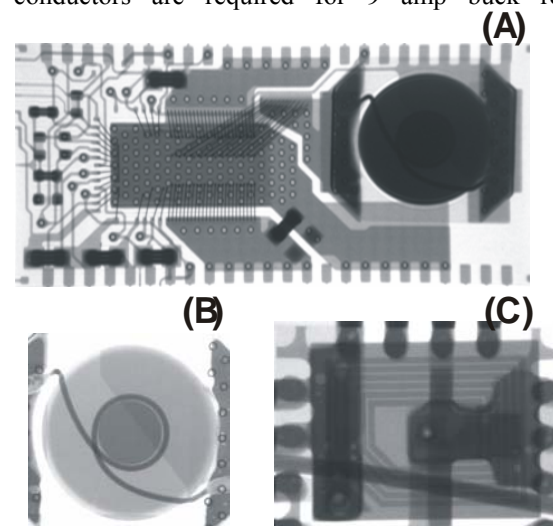

Figure 9: (A) X-ray of EN5360 (B) X-ray energy optimized to view the inductor, and (C) X-ray of EN5312

VI. LESSONS LEARNED FROM COMMERCIAL DEVICES

Below are some lessons we have learned, either through our experiments, or through the literature, concerning the commercial components we have tested.

1. Some of the devices have lower dependence of the efficiency vs Input/Output voltage ratio.
2. The internal gain loop compensation of the EQ5352D is designed for a maximum load capacitance of 60 μF .
3. For the fixed-output converters the output voltage tolerance is $\pm 2\%$ maximum.
4. EMI noise is drastically reduced by packing all components to reduce the current switching loop.
5. We need to further understand the parameters that go into the power losses such as the resistances of the output the output NFET & PFET transistors, integrated inductors etc.
6. We need to further understand the functions or characteristics necessary for the LHC applications in the case commercial devices don't pass all the radiations tests and an ASIC needs to be developed.

VII. PROOF-OF-PRINCIPLE PCB MODULE UNDER DEVELOPMENT

Our tests to date give us some confidence that we can package a DC-DC regulator with an air coil on the same PCB as the Silicon sensor and the ABCD readout chips as shown below.

Since an EN5360 chip (with integrated inductor) passed 100 Mrads with Co-60 source, a chip from the same family with an external inductor is a logical choice. This is being designed to be on a small PCB as a daughter card that can be soldered or plugged into the mother board. This shall supply only the 3.5 V analog power to the ABCD chip while the 4 V digital power shall be from a laboratory power supply.

VIII. CONCLUSION

Our current plans are to build a PCB module to demonstrate the proof of principle in the next few months. Subsequently, with funding approval, it will be possible to continue to research this approach along with participation by the LHC groups. Our work is initiated under the auspicious of the ATLAS silicon tracker upgrade program. This technique is applicable to many other LHC detectors.

IX. REFERENCES

1. David Morison "Power Chips with Magnetics are going Mainstream" Editor Power Electronics Technology Magazine July 2007 issue
2. Power Electronics 3rd edition authors Mohan, Underland, Robbins. John Wiley & Sons Inc. ISBN 0-471-22693-9 pages 164-172
3. Peter Hazucha et al: pages 838-845 IEEE Journal of Solid State Circuits, Vol. 40. NO. 4. April 2005.
4. Gerhard Schrom et al: pages 4702-4707 2004 35th Annual IEEE Power Electronics Specialists Conference.
5. Gerhard Schrom et al: pages 263-268 Proceedings of the 2004 International Symposium on Low Power Electronics and Design (ISLPED '04)

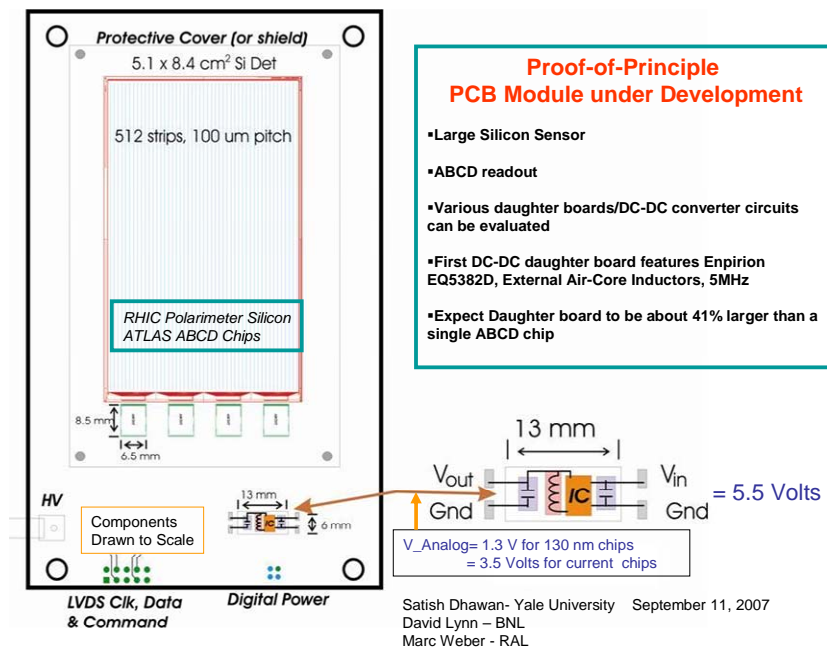

Figure 10: Illustration of PCB module under development for use in DC-DC converter power and noise test